

INSTALLATION INSTRUCTIONS PE COMPRESSION X PLAIN OR BUTTWELD ADAPTER COUPLINGS

IMPORTANT

For use on:

Polyethylene (PE) gas pipe meeting the requirements of ASTM D 2513

Pressure Rating: Designed to meet or exceed pressure rating of PE pipe per 49 CFR Part 192 and ASTM D 2513

Operating Temperature: -20 to 140° F

Material: Carbon Steel

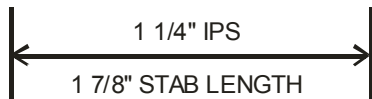

PLAIN OR WELD END

1. BEFORE WELDING ADAPTER COUPLING, REMOVE THE SEAL RING AND COMPRESSION NUT FROM THE COUPLING BODY AND PLACE IN THE PLASTIC BAG IN WHICH THE COUPLING WAS SHIPPED.
2. WELD COUPLING BODY FOLLOWING YOUR COMPANIES WELDING PROCEDURES.
3. ALLOW WELDED COUPLING TO COOL TO AMBIENT TEMPERATURE BEFORE INSTALLING PE PIPE.
4. IF USING COMPRESSION COUPLING, FOLLOW COMPRESSION COUPLING MANUFACTURER'S INSTRUCTIONS.

PE COMPRESSION END

5. VERIFY THAT THE COUPLING IS THE CORRECT SIZE FOR THE POLYETHYLENE (PE) PIPE. VERIFY THE SDR (OR WALL THICKNESS) OF THE PIPE MATCHES THE SDR (OR WALL THICKNESS) STAMPED ON THE END OF THE STIFFENER.
6. CUT PE PIPE ENDS SQUARE, DEBURR INSIDE AND OUTSIDE, CLEAN THOROUGHLY TO ASSURE THERE IS NO DIRT, GREASE, OIL, ETC. ON ASSEMBLY AREA OF PIPE.
7. MARK STAB LENGTH ON PE PIPE (SEE EXAMPLES FOR CORRECT PIPE OR TUBING SIZE AND CORRESPONDING STAB LENGTH).
8. LOOSEN COMPRESSION NUT AND INSERT PE PIPE UNTIL IT BOTTOMS IN COUPLING.
9. TIGHTEN COMPRESSION NUT TO APPROXIMATELY 90 FT. LBS. LINE MARKED FOR STAB LENGTH SHOULD BE NO MORE THAN 5/8" FROM FACE OF COMPRESSION NUT, IF NOT, REASSEMBLE.
10. TO ASSURE PROPER ASSEMBLY AND TO COMPLY WITH 49 CFR 192 SUBPART J—TEST REQUIREMENTS, THE JOINT SHALL BE LEAK TESTED.

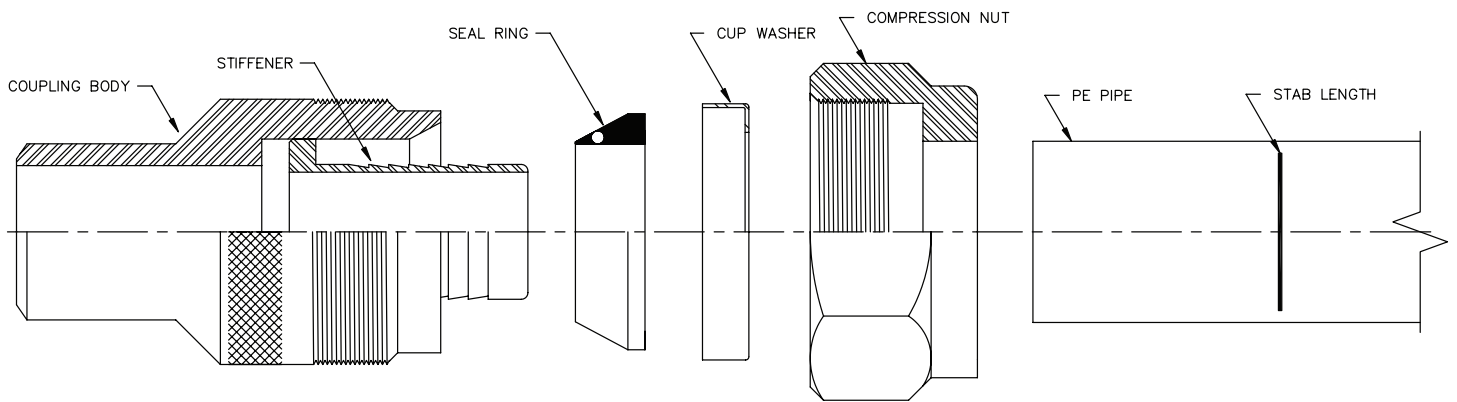

ORDER OF PARTS FOR 1 1/4" IPS PE COMPRESSION END

